

Magnetic Sensor ICs

Omnipolar Detection High Performance Hall-Effect Sensor IC



● General Description

Using CMOS process, the AS1805 is designed for high performance omnipolar detection hall-effect application, such as cover switch, contactless switch, solid state switch and lid close sensor etc battery operation. The hall IC integrated an on-chip hall voltage generator for magnetic sensing, a comparator that amplifiers the hall voltage, a Chopper amplifier, a Schmitt trigger to provide switching hysteresis for noise rejection, and a complementary output.

AS1805 is designed to respond to alternating North and South poles. When the magnetic flux density (B) is larger than operate point (B_{OP}), the output will be turned on (low), the output is held until the magnetic flux density (B) is lower than release point (B_{RP}), then turn off (high).

The device is available in SOT23-5L, SOT553 and SIP-3L Packages and is rated over the -40°C to 125°C. The all packages are RoHS and Green compliant.

● Features

- Input Voltage Range : 2.5V to 5.5V
- Micro-power consumption ideal for battery power applications
- Omnipolar Operation, easy to use as output
- Very high sensitivity hall sensor
- CMOS process technology
- Chopper stabilization amplifier stage
- Magnetic Sensitivity (typical)
B_{OP}= ±35Gauss, B_{RP}= ±32Gauss
- Good RF noise immunity
- No need pull-up resistor
- Small Solution Size
- RoHS & Green Compliant
- SOT23-5L, SOT553 and SIP-3L Packages
- -40°C to +125 °C Temperature Range

● Applications

- Smart Meter
- Cover switch
- Contact-less switch

■ Ordering Information

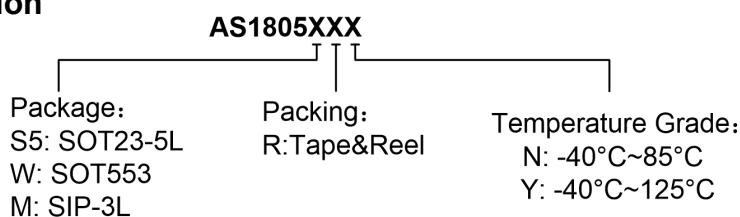

Part Number	B _{OP} (Gauss)	B _{RP} Gauss)	Package Type	Package Qty	Temperature	Eco Plan
AS1805S5RN	±35Gauss	±32Gauss	SOT23-5L	7-in reel 3000pcs/reel	-40~85°C	Green
AS1805WRN	±35Gauss	±32Gauss	SOT553	7-in reel 3000pcs/reel	-40~85°C	Green
AS1805MBN	±35Gauss	±32Gauss	SIP-3L	1000pcs/Package	-40~85°C	RoHS
AS1805S5RY	±35Gauss	±32Gauss	SOT23-5L	7-in reel 3000pcs/reel	-40~125°C	Green
AS1805WRY	±35Gauss	±32Gauss	SOT553	7-in reel 3000pcs/reel	-40~125°C	Green
AS1805MBY	±35Gauss	±32Gauss	SIP-3L	1000pcs/Package	-40~125°C	RoHS

■ **Marking & Pin Assignment**

SOT23-5L:

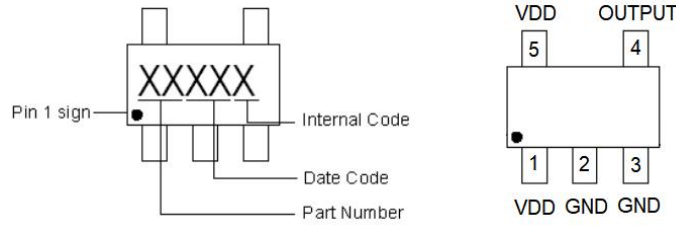

Pin Name	Pin No. SOT23-5L	I/O	Pin Function
VDD	1, 5	P	Input Power Supply
GND	2, 3	P	Ground
OUTPUT	4	O	Output Pin

SOT553:

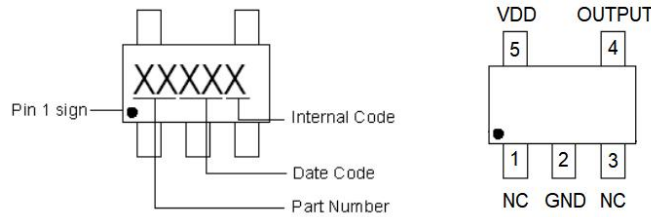

Pin Name	Pin No. SOT553	I/O	Pin Function
NC	1, 3	-	Not Connected
GND	2	P	Ground
OUTPUT	4	O	Output Pin
VDD	5	P	Input Power Supply

SIP-3L

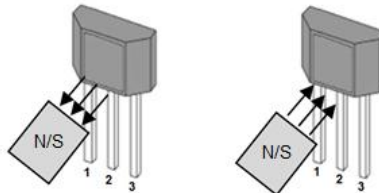

Pin Name	Pin No. SIP-3L	I/O	Pin Function
VCC	1	P	Input Power Supply
GND	2	P	Ground
OUTPUT	3	O	Output Pin.

■ **Typical Application Circuit**

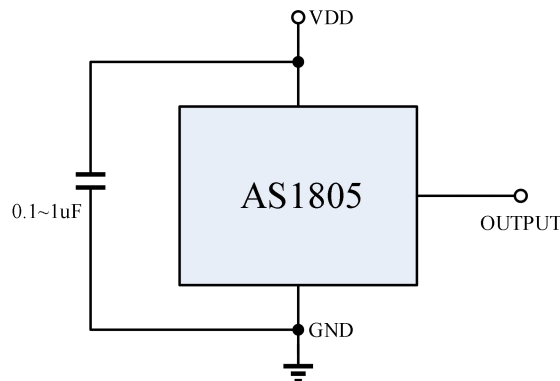

Figure 1, Typical Application Circuit of AS1805

■ **Block Diagram**

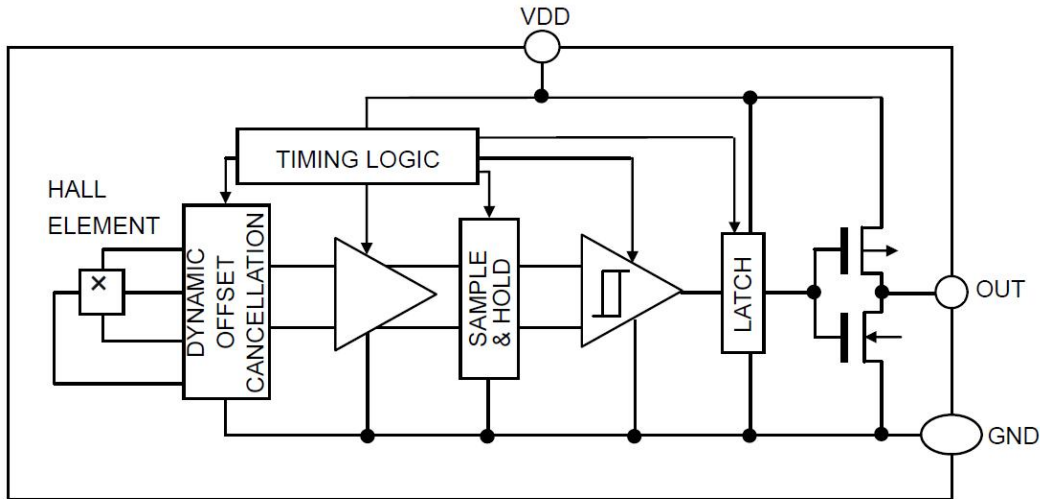

Figure 3, Block Diagram of AS1805

■ **Absolute Maximum Ratings¹** ($T_A=25^\circ\text{C}$, unless otherwise noted)

Parameter	Symbol	Rating	Unit
V_{DD} Pin to GND	V_{DD}	-0.3 to 5.5	V
Output Pin to GND	V_{OUTPUT}	-0.3 to $V_{DD} + 0.3$	V
Max. Continuous Output Current	I_{OUTMAX}	2.0	mA
Package Power Dissipation	SOT23-5L/SOT553	P_D	180
	SIP-3L	P_D	400
ESD (HBM)	ESD	8000	V
Operating Junction Temperature Range	T_{OP}	-40 to +125	$^\circ\text{C}$
Maximum Soldering Temperature (at leads, 10 sec)	T_{LEAD}	300	$^\circ\text{C}$

■ **Recommended Operating Conditions²**

Parameter	Symbol	Rating	Unit
V_{DD} Pin to GND	V_{DD}	2.5 to 5.5	V
Continuous Output Current	I_{OUT}	1.0	mA
Operating Temperature Range	T_{OP}	-40 to +125	$^\circ\text{C}$

Note: 1: Stresses above those listed in absolute maximum ratings may cause permanent damage to the device. Functional operation at conditions other than the operating conditions specified is not implied. Only one absolute maximum rating should be applied at any one time.

2: The device is not guaranteed to function outside of its operating conditions.

■ **Electrical Characteristics**

($T_A = -40$ to $+125^\circ\text{C}$ unless otherwise noted. Typical values are at $T_A = +25^\circ\text{C}$, $V_{DD} = 5.0\text{V}$) (1mT=10Gauss)

Symbol	Parameter	Conditions	Min.	Typ.	Max.	Unit
V_{DD}	Input Voltage		2.5	-	5.5	V
$I_{DD}(AVG)$	Supply Current	Average supply current, $T_A=25^\circ\text{C}$	-	1.1	2.0	mA
V_{OH}	Output Off Voltage (High side)	$I_{OUT}=+1\text{mA}$	$V_{DD}-0.3$	$V_{DD}-0.1$	$V_{DD}+0.3$	V
V_{OL}	Output On Voltage (Low side)	$I_{OUT}=-1\text{mA}$	-0.3	0.1	+0.3	V
Magnetic Para.						
B_{OPS}	Magnetic Operating Point		-	35	55	Gauss
B_{OPN}			-55	-35	-	
B_{RPS}	Magnetic Release Point		15	32	-	Gauss
B_{RPN}			-	-32	-15	
B_{HYS}	Hysteresis Window		-	3	-	Gauss

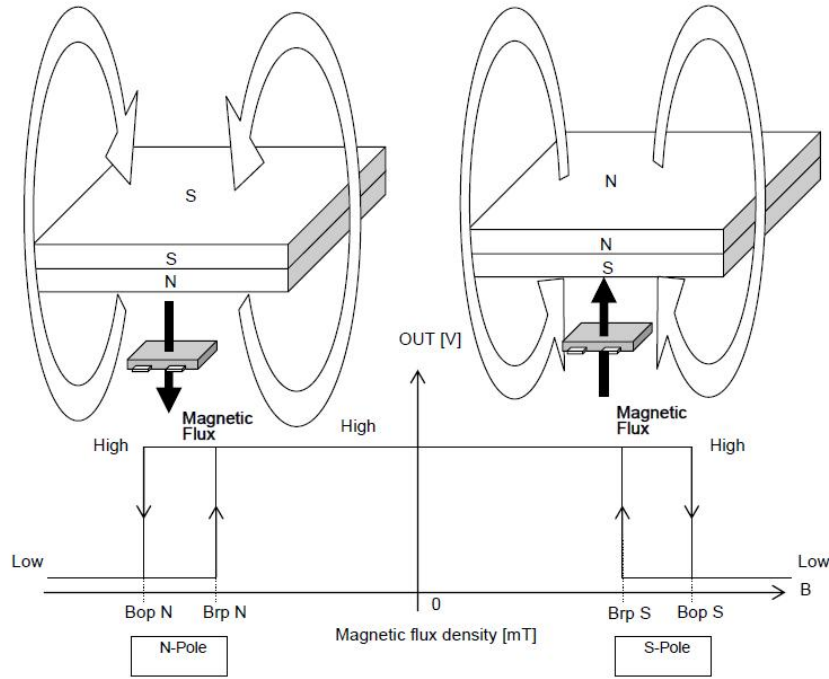
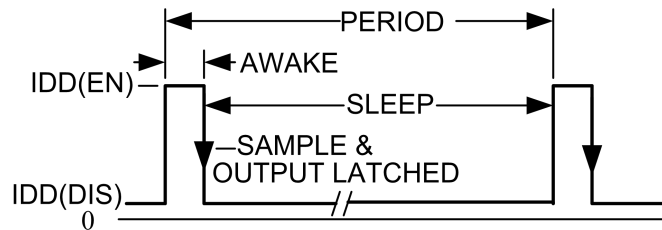

Fig 4, Magnetic Operation Characteristic of AS1805

■ **Function Description**



Chopper-Stabilized Technique

The Hall element can be considered as a resistor array similar to a Wheatstone bridge. A large portion of the offset is a result of the mismatching of these resistors. These devices use a proprietary dynamic offset cancellation technique, with an internal high-frequency clock to reduce the residual offset voltage of the Hall element that is normally caused by device over-molding, temperature dependencies, and thermal stress. The chopper-stabilizing technique cancels the mismatching of the resistor circuit by changing the direction of the current flowing through the Hall plate using CMOS switches and Hall voltage measurement taps, while maintains the Hall voltage signal that is induced by the external magnetic flux. The signal is then captured by a sample-and-hold circuit and further processed using low-offset bipolar circuitry. This technique produces devices that have an extremely stable quiescent Hall output voltage, are immune to thermal stress, and have precise recoverability after temperature cycling. A relatively high sampling frequency is used for faster signal processing capability can be processed.

Magnetic Field Detection Mechanism

The Hall IC cannot detect magnetic fields that run horizontal to the package top layer. Be certain to configure the Hall IC so that the magnetic field is perpendicular to the top layer.

Operation

The output of this device switches low (turns on) when a magnetic field perpendicular to the Hall sensor exceeds the operate point B_{OPS} (or is less than B_{OPN}). After turn-on, the output is capable of sinking up to 1mA and the output voltage is $V_{OUT(ON)}$. When the magnetic field is reduced below the release point B_{RPS} (or increased above B_{RPN}), the device output switches high (turns off). The difference between the magnetic operates and release points are the hysteresis (B_{hys}) of the device. This built-in hysteresis allows clean switching of the output even in the presence of external mechanical vibration and electrical noise.

■ Applications:

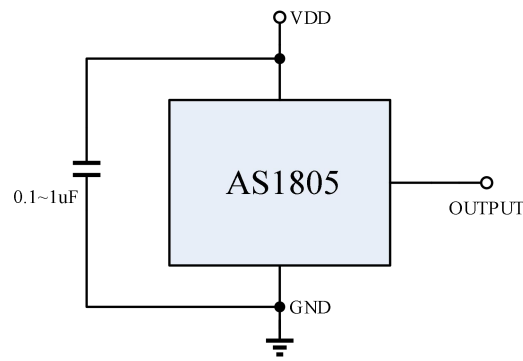

AS1805's pole-independent sensing technique allows for operation with either a north or south poles magnet orientation, enhancing the manufacturability of the device. The state-of-the-art technology provides the same output polarity for either pole face.

C serves two purposes: minimizing ripples on the input voltage and enhancing immunity from RF transmission noises within close proximity. Recommended values are between 100nF and 1uF. The larger the capacitance, the better the noise immunity is for the AS1805.

It is strongly recommended that an external bypass capacitor be connected (in close proximity to the Hall sensor) between the supply and ground of the device to reduce both external noise and noise generated by the chopper-stabilization technique. This is especially true due to the relatively high impedance of battery supplies. The simplest form of magnet that will operate these devices is a bar magnet with either pole near the branded surface of the device.

Thermal Considerations

The maximum IC junction temperature should be restricted to 125°C under normal operating conditions. This restriction limits the power dissipation of the AS1805. Calculate the maximum allowable dissipation, $P_{D(max)}$, and keep the actual dissipation less than or equal to $P_{D(max)}$. The maximum-power-dissipation limit is determined using following equation:

$$P_{D(MAX)} = \frac{125^{\circ}\text{C} - T_A}{R_{\theta JA}}$$

Where, T_A is the maximum ambient temperature for the application. $R_{\theta JA}$ is the thermal resistance junction-to-ambient given in Power Dissipation Table.

■ Package Information

SOT553:

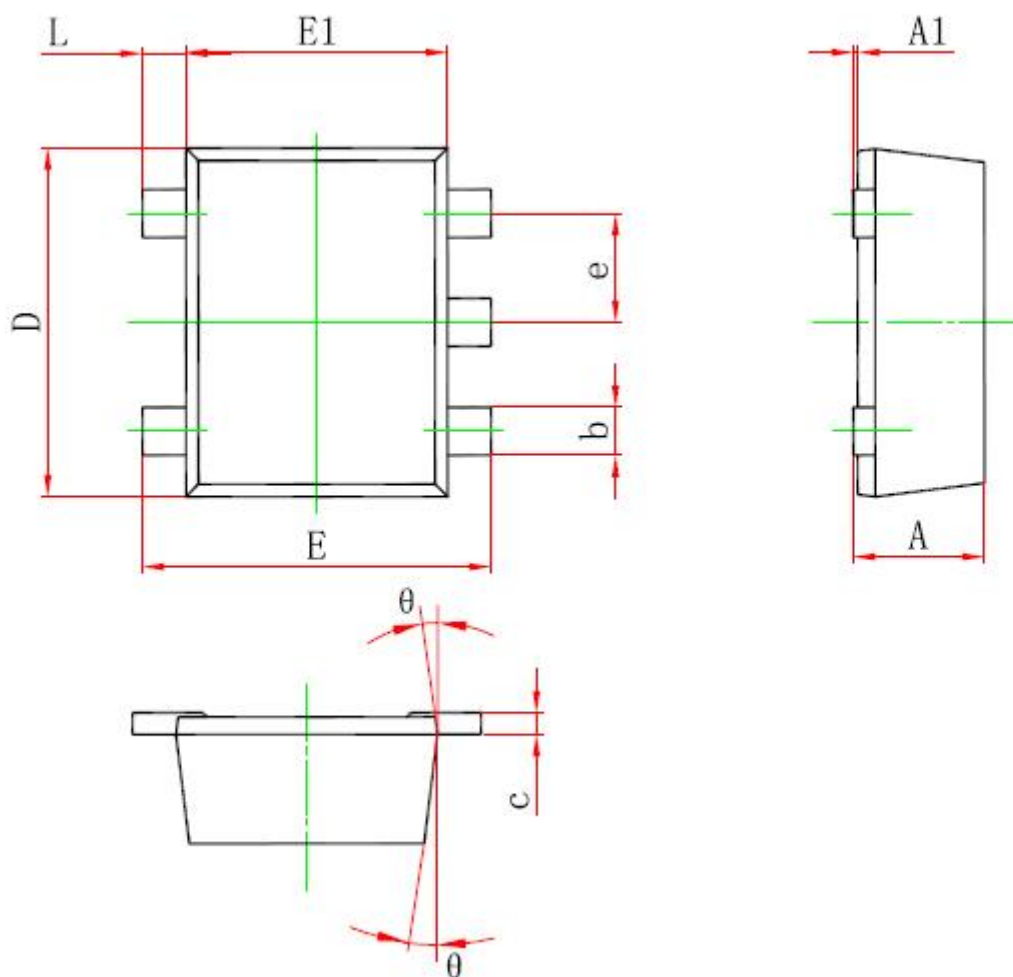

Symbol	Dimensions In Millimeters		Dimensions In Inches	
	Min.	Max.	Min.	Max.
A	0.525	0.600	0.021	0.024
A1	0.000	0.050	0.000	0.002
e	0.450	0.550	0.018	0.022
c	0.090	0.160	0.004	0.006
D	1.500	1.700	0.059	0.067
b	0.170	0.270	0.007	0.011
E1	1.100	1.300	0.043	0.051
E	1.500	1.700	0.059	0.067
θ	7° REF		7° REF	
L	0.100	0.300	0.004	0.012

SOT23-5L:

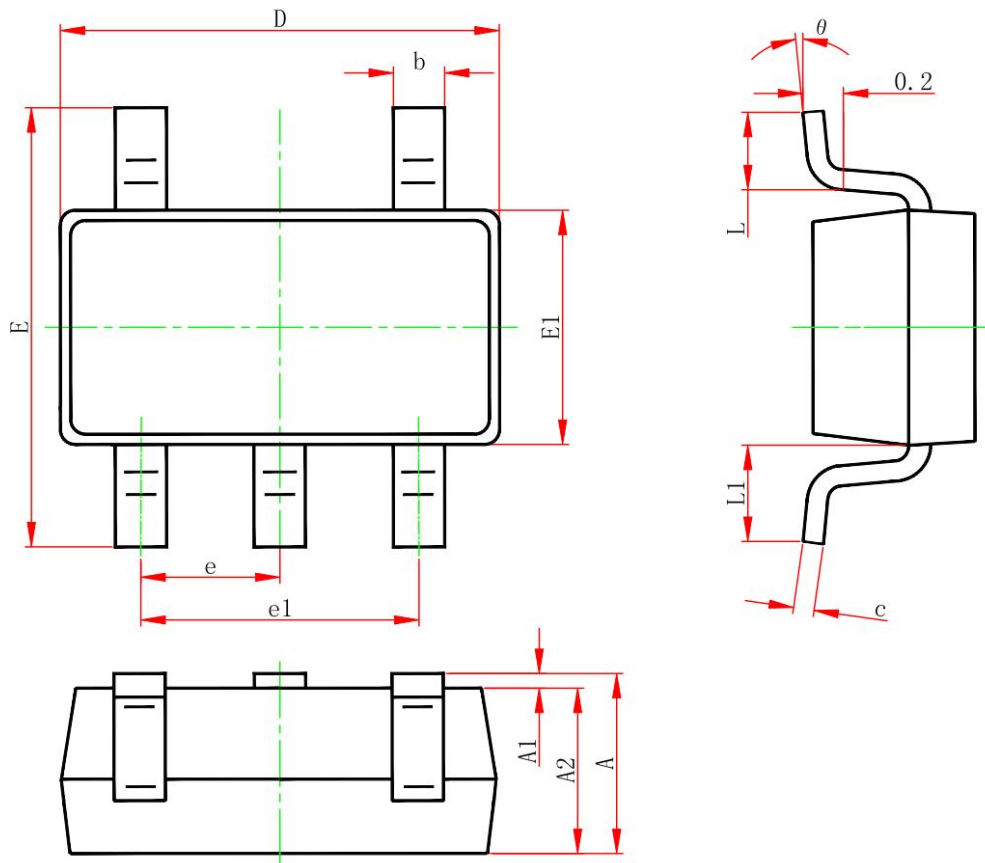

Symbol	Dimensions In Millimeters		Dimensions In Inches	
	Min.	Max.	Min.	Max.
A	1.050	1.250	0.041	0.049
A1	0.000	0.100	0.000	0.004
A2	1.050	1.150	0.041	0.045
b	0.300	0.500	0.012	0.020
c	0.100	0.200	0.004	0.008
D	2.820	3.020	0.111	0.119
E1	1.500	1.700	0.059	0.067
E	2.650	2.950	0.104	0.116
e	0.950(BSC)		0.037(BSC)	
e1	1.800	2.000	0.071	0.079
L	0.300	0.600	0.012	0.024
L1	0.600REF		0.024REF	
θ	0°	8°	0°	8°

SIP-3L:

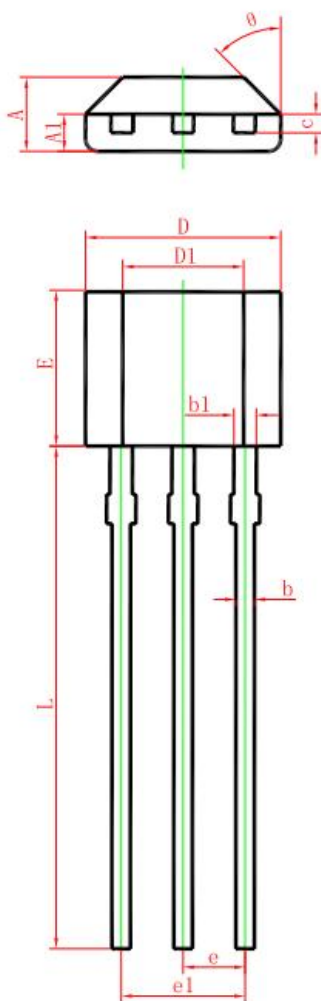

Symbol	Dimensions In Millimeters		Dimensions In Inches	
	Min.	Max.	Min.	Max.
A	1.420	1.620	0.056	0.064
A1	0.660	0.860	0.026	0.034
b	0.330	0.480	0.013	0.019
b1	0.400	0.510	0.016	0.020
c	0.330	0.510	0.013	0.020
D	3.900	4.100	0.154	0.161
D1	2.280	2.680	0.090	0.106
E	3.050	3.250	0.120	0.128
e	1.270 TYP.		0.050 TYP.	
e1	2.440	2.640	0.096	0.104
L	14.350	14.750	0.565	0.581
θ	45° TYP.		45° TYP.	

■ **Packing Information**

SOT553/SOT23-5L:

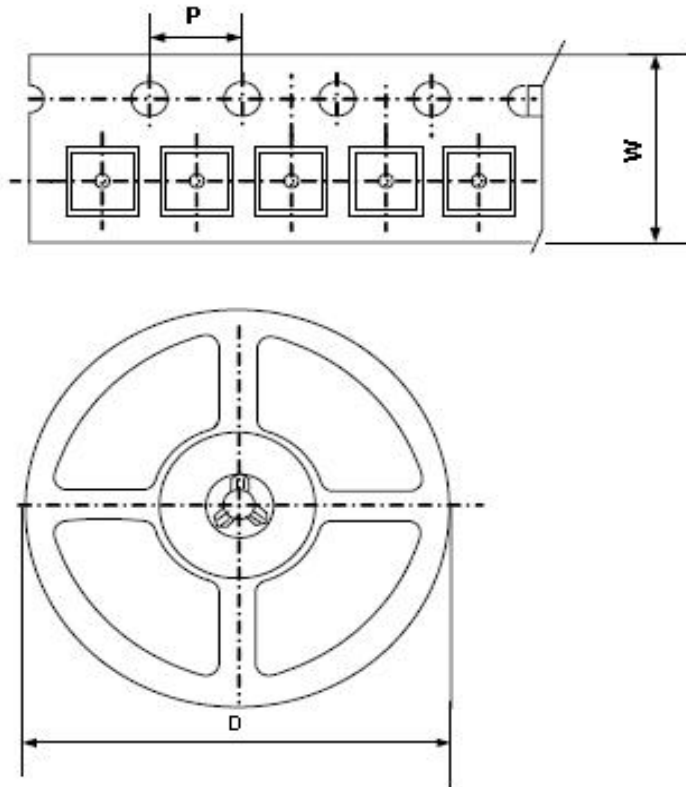

QUADRANT ASSIGNMENTS FOR PIN 1 ORIENTATION IN TAPE

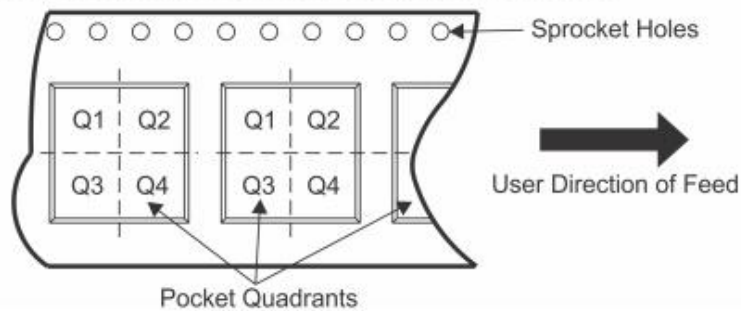

Device	Package Type	SPQ	Carrier Width (W)	Pitch(P)	Reel Size(D)	Pin1 Quadrant
AS1805WRN(Y)	SOT553	3000pcs	8.0±0.1 mm	4.0±0.1 mm	180±1 mm	Q3
AS1805S5RN(Y)	SOT23-5L	3000pcs	8.0±0.1 mm	4.0±0.1 mm	180±1 mm	Q3

Note: Carrier Tape Dimension, Reel Size and Packing Minimum

■ **Packing Information**

SIP-3L:

- 1, Packing type: Bulk
- 2, Packing minimum: 1000pcs

■ Revision History:

NOTE: Page numbers for previous revisions may differ from page numbers in the current version.

Changes from Revision 1.2 (January 2024) to Revision 1.3 Page

-
- Modify the SOT23-5L Pin Assignment..... 2

Changes from Revision 1.1 (Jan. 2023) to Revision 1.2 Page

-
- Add SIP3L Package in General Description and Features..... 1
 - Add SIP3L Package in the Ordering Information and Pin Assignment1/2
 - Add SIP3L Package Power Dissipation in Maximum Ratings.....3
 - Add SIP3L Package Dimension in Package/Packing Information.....8/9

Changes from Revision 1.0 (Jan. 2022) to Revision 1.1 Page

-
- Add SOT553 Package in General Description and Features..... 1
 - Add SOT553 Package in the Ordering Information and Pin Assignment1/2
 - Add SOT553 Package Dimension in Package/Packing Information.....6/8

Changes from Original (October 2019) to Revision 1.0 Page

-
- Initial Release Specification 1